

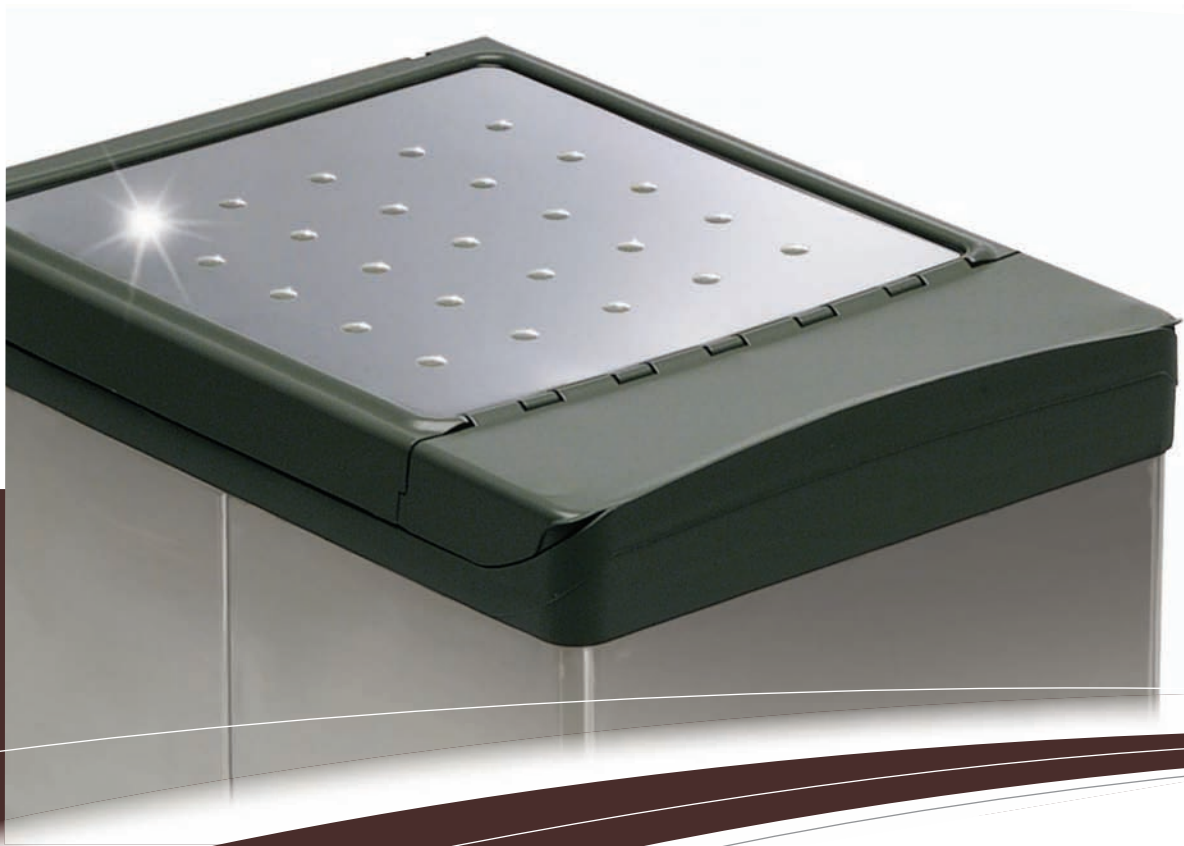

romagnaplastic
BUILT-IN KITCHEN SOLUTIONS



Built-in kitchen bin solutions

Waste management systems

Index



Waste Bins - door mounted..... **3**



Waste Bins - pull-out **4**



Waste Bins - for large drawers **6**





Optional Item - door mounting kit **6**

Legend

Capacity in litres:



Materials:

-  polypropylene PP
-  polystyrene PS
-  polyamide PA
-  stainless steel
-  metal

Assembly time:



Cabinet size:



door



big drawer

Extraction:



automatic



manual

Automatic lid opening:



Bins quantity:



Examples of bucket layouts



Waste Bins - Door Mounted

208



TOT:5



2,5 min



min300mm



automatic



automatic

The lid opens by means of a patented automatic mechanism.
Code: **1-460-320** Colour: White

Available September 2008

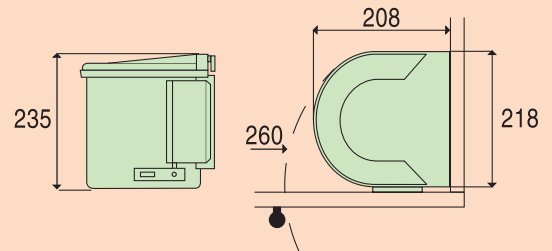

270



TOT:13



2 min



min400mm



automatic



automatic

High impact plastic, economical mounted bin. The lid opens by means of a patented automatic mechanism.

Code: **1-460-322** Colour: White

Available September 2008

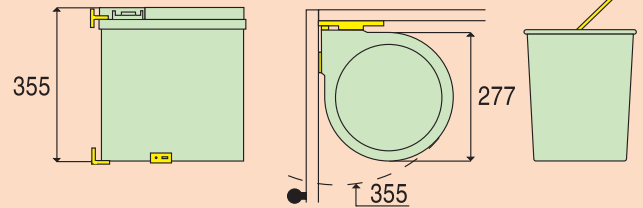

272



TOT:13



2 min



min400mm



automatic



automatic



inox

Easy to clean metal, door mounted bin. The lid opens by means of a patented automatic mechanism.

Code: **1-460-326** Colour: White

Code: **1-460-328** Colour: Metallic Grey

Available October 2008

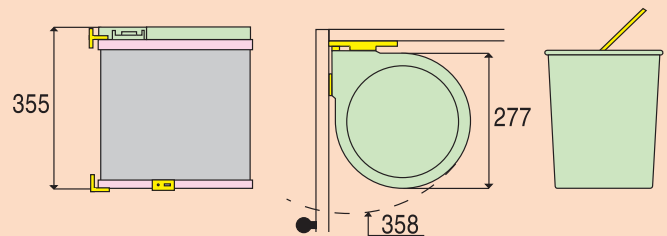

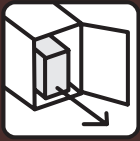

Waste Bins - Pull-Out

226

Enrico Tommasini Design

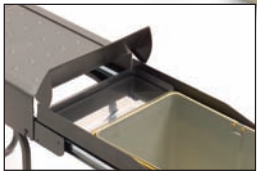

- TOT:20
- 2,5 min
- min300mm
- manual
- automatic

The front part of the lid lifts automatically for easy access to the little utensil tray. The lid is easy to unhook (to facilitate cleaning) and has been designed to rest on sponges, gloves..
Tested at 100.000 cycles.

Code: **1-460-224** Colour: Quartz Grey, Light Grey

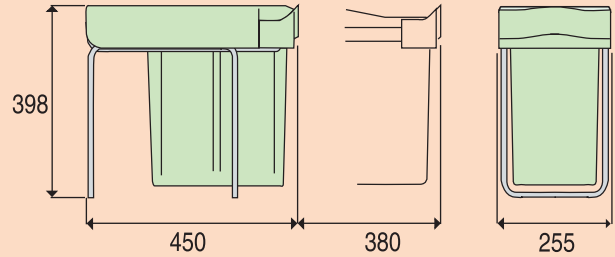

227

Enrico Tommasini Design



- TOT:28
- 2,5 min
- min300mm
- manual
- automatic

The front part of the lid lifts automatically for easy access to the rear bucket and its removal. The lid is easy to unhook (to facilitate cleaning) and has been designed to rest on sponges, gloves..
Tested at 100.000 cycles.

Code: **1-460-225** Colour: Quartz Grey, Light Grey

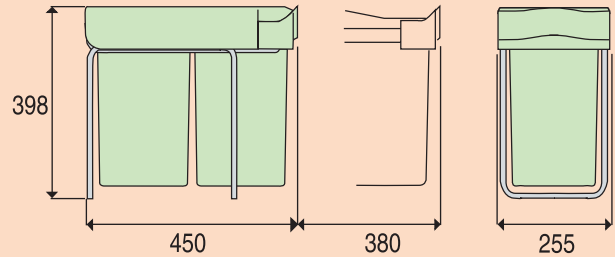

250

Lucci / Orlandini Design



- TOT:28
- 5 min
- min450mm
- automatic
- manual
- automatic
- inox

Bucket with handles designed to fix the plastic liner, the several colours of the handle make waste separation easy. Patented automatic extraction mechanism, running on ball bearing slides, tested with 10kg weight up to 50.000 cycles, fits in units of 350mm when worked manually.

Code: **1-460-308** Colour: Quartz Grey, Light Grey

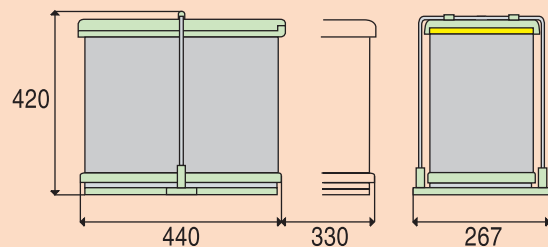



Waste Bins - Pull-Out

503

Enrico Tommasini Design

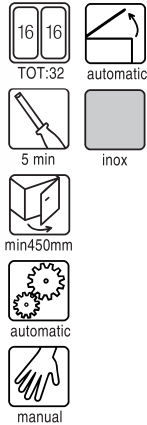

Patented automatic extraction mechanism, running on ball bearing slides. The lid is easy to unhook to facilitate cleaning, and has been designed to rest sponges and gloves on. Body and upper insert are made of stainless steel. Buckets with two handles each, designed to fix the liner, handles differently coloured for an easier waste separation. Fits in units of 400mm when worked manually.

Code: **1-460-330** Colour: Quartz Grey

Available September 2008

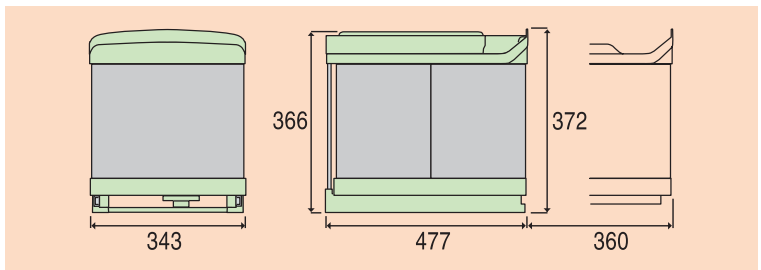

55070L

Enrico Tommasini Design



Huge double bins for the larger household. Totally extractable steel ball slides. Automatic lid and associated metal support to be fixed laterally. Can hold up to 25kgs.

Code: **1-460-334** Colour: Quartz Grey, Light Grey

Available October 2008

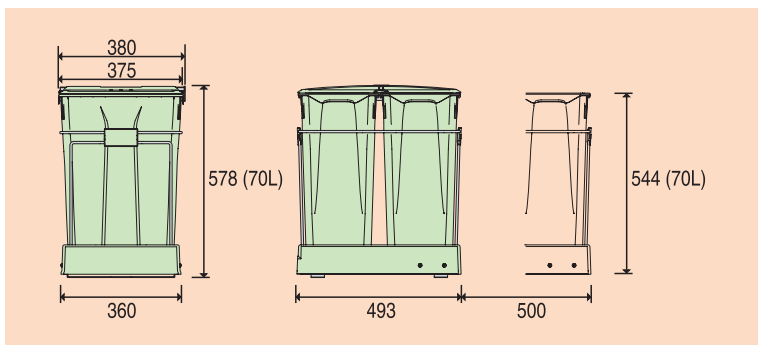

55160L

Enrico Tommasini Design



Huge double bins for the larger household. Totally extractable steel ball slides. Automatic lid and associated metal support to be fixed laterally. Can hold up to 25kgs.

Code: **1-460-336** Colour: Quartz Grey, Light Grey

Available October 2008

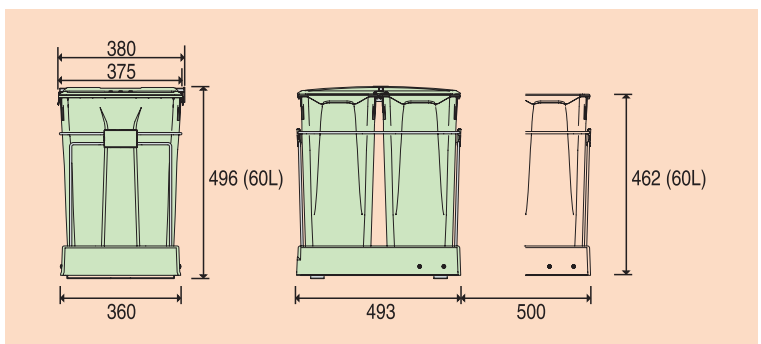



Waste Bins - For Large Drawers

921LS

Lucci / Orlandini Design

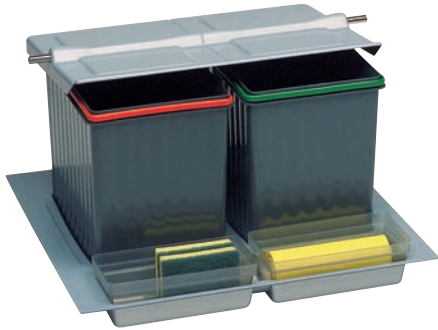

- Equipment:
- 1 main-tray
 - 2 removable trays
 - 2 buckets with two handles each, designed to fix the liner, handles coloured differently for an easier waste separation
 - 1 automatic lid

Code: **1-460-332** Colour: Metallic Grey, Anthracite Grey

Available October 2008

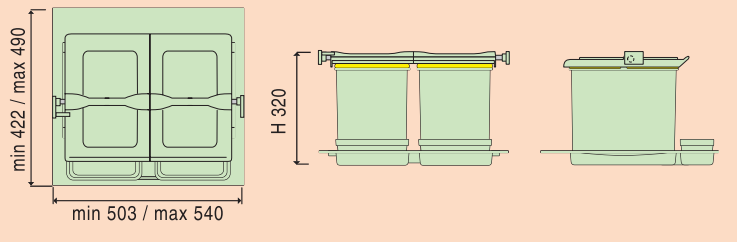

906

Lucci / Orlandini Design

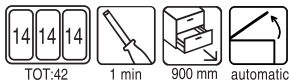

- Equipment:
- 1 main-tray
 - 3 removable trays
 - 3 buckets with two handles each, designed to fix the liner, handles coloured differently for an easier waste separation

Code: **1-460-302** Colour: Metallic Grey, Anthracite Grey

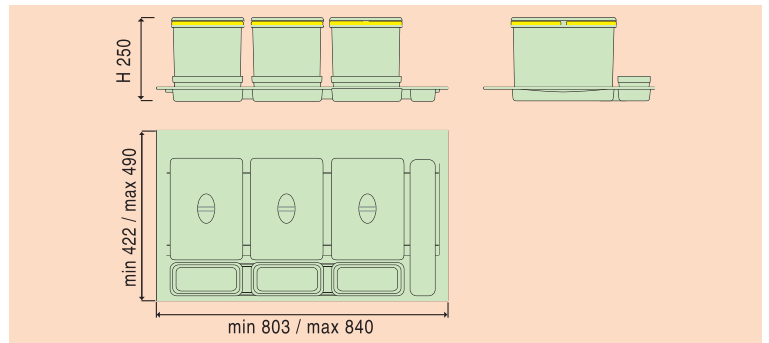

Optional Item - Door Mounting Kit

555



Door mounting fixing kit. Optional item for 550 and 551. It includes 4 painted-metal elements, bolts and screws necessary to assembling and fitting instructions.

Code: **1-460-338** Colour: Metallic Grey

Available October 2008

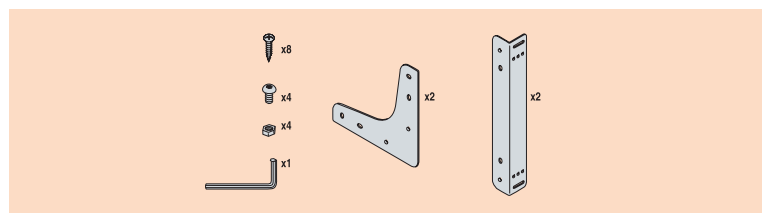



Waste Bins - For Large Drawers

922LS

Lucci / Orlandini Design

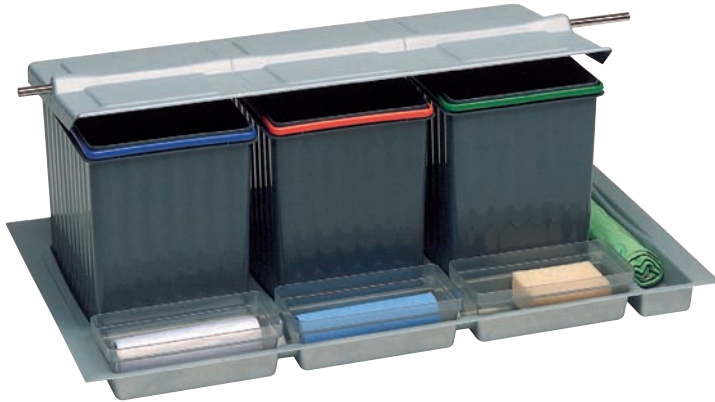

- Equipment: **1** main-tray
3 removable trays
3 buckets with two handles each, designed to fix the liner, handles coloured differently for an easier waste separation
1 automatic lid

Code: **1-460-303**

Colour: Metallic Grey, Anthracite Grey

Available November 2008

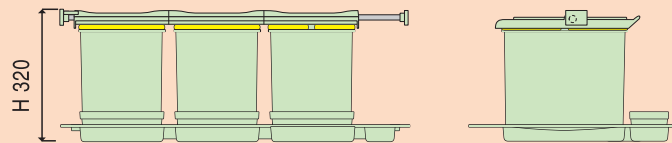
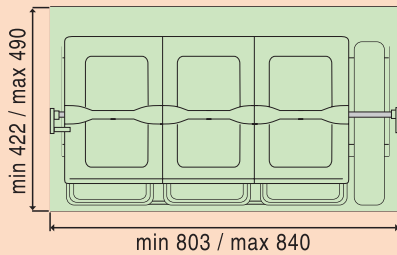
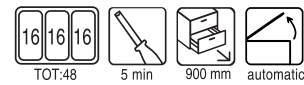

924LS

Lucci / Orlandini Design



- Equipment: **1** main-tray
4 removable trays
2 chromium-plated wire racks, one for papers and one for storing cleaning products
1 dustpan + broom
3 buckets with two handles each, designed to fix the liner, handles coloured differently for an easier waste separation
1 automatic lid

Code: **1-460-311**

Colour: Metallic Grey, Anthracite Grey

Available October 2008

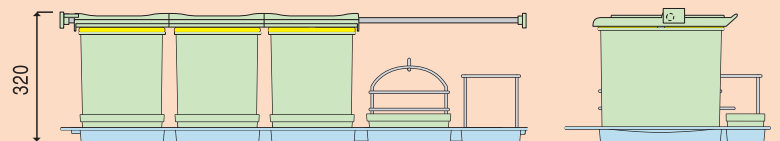
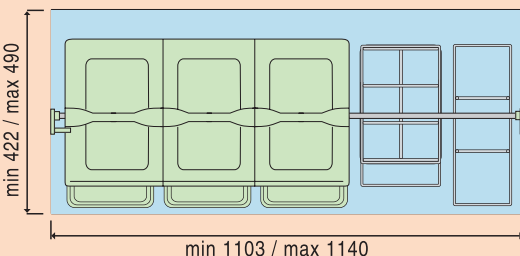

For more information, Please call us or visit
www.lincolngroup.com.au